

**IOM-Heliflow-0507**

# **HELIFLOW**

## **INSTALLATION, OPERATION AND MAINTENANCE MANUAL**

Graham Corporation • Corporate and Sales Headquarters: 20 Florence Avenue, Batavia, New York 14020 USA  
Phone.: 585-343-2216 Fax: 585-343-1097 e-mail: equipment @ graham-mfg.com Web site:www.graham-mfg.com

T



## TABLE OF CONTENTS

<b>SECTION I - INSTALLATION</b> .....	<b>3</b>
<b>1.1 Mounting</b> .....	<b>3</b>
<b>1.2 Piping-up (See Figure I)</b> .....	<b>3</b>
<b>SECTION II - OPERATION</b> .....	<b>3</b>
<b>2.1 Startup (See Figure I)</b> .....	<b>3</b>
<b>SECTION III – MAINTENANCE / INSPECTION</b> .....	<b>4</b>
<b>3.1 Disassembly (See Figure I)</b> .....	<b>4</b>
<b>3.2 Reassembly (See Figure I)</b> .....	<b>4</b>
<b>3.3 Miscellaneous Notes (See Figure I)</b> .....	<b>5</b>
<b>SECTION IV - SAFETY CONCERNS / PRECAUTIONS</b> .....	<b>5</b>
<b>SECTION V – SPARE AND REPLACEMENT PARTS</b> .....	<b>6</b>
<b>FIGURE I</b> .....	<b>7</b>
<b>HELIFLOW HEAT EXCHANGER SPECIFICATION</b> .....	<b>8</b>

## **SECTION I - INSTALLATION**

### **1.1 *Mounting***

Small Heliflow heat exchangers can be supported by their piping; the support bracket shown on the exploded view (Figure I) may not be required. However, larger Heliflows do require mounting brackets, or mounting lugs, to support the extra weight associated with these larger sizes.

The unit can usually be mounted on any convenient support; below, above, or to the side - on a base plate, a column or wall, the side of a piece of equipment, or hung from an overhead surface. If a specific orientation is required, a drawing indicating this can be furnished with your Heliflow heat exchanger order. Note that certain condensing or vaporizing applications require that the unit be mounted with the tubeside manifolds in the vertically upward or downward position.

### **1.2 *Piping-up (See Figure I)***

Normally the fluid with the least fouling tendency (and/or higher operating pressure ) is circulated in the Heliflow coil by connecting its piping to the manifolds (items 6 and 7) that extend through the base plate. The other fluid's piping is connected to the casing-side circuit through the threaded openings in the base plate (item 4). To obtain counter-current flow, which is normally desired, the inlet for one fluid and the outlet for the other must be side by side. Thus, if the coil side fluid enters the lower manifold (item 7), the casing side fluid should exit from the lower base plate opening.

Your Graham representative can supply a drawing of any standard Heliflow heat exchanger showing dimensions, pipe sizes, connection specification, etc.

## **SECTION II - OPERATION**

### **2.1 *Startup (See Figure I)***

1. Open all vents in piping to the Heliflow including removal of the casing vent plug (item 11). Close each vent and/or replace the plug when fluid begins to flow from its opening, indicating that all air has been expelled. If fluid is hot, or other than water, customer may want to consider installing ¼ inch ball valves on the vent and drains for easier and safer start-up.
2. Tighten base plate nuts (item 1) and manifold nuts (item 2) after two or three hours, and check their tightness after 24 hours. These nuts occasionally loosen up during transit and initial start-up. Suggested torque values for compressed fiber type gaskets are as follows:

Casing Bolt Torque values

Cast Iron Casing: 45 ft-lb

Cast Steel Casing: 75 ft-lb

Fabricated Casing: 100 ft-lb

## ***Graham Corporation***

3. Always start up the cold fluid side prior to the hot side to minimize thermal shock and possibility of water hammer.
4. If equipment is supplied with a pressure relief device, be sure that it is piped or pointed away from personnel or high traffic area in case of discharge.
5. Check nameplate for design pressure and temperature limits so that operation personnel are aware of maximum allowable limits and these are not exceeded during operation of equipment.

## **SECTION III – MAINTENANCE / INSPECTION**

### ***3.1 Disassembly (See Figure I)***

If gaskets begin to leak after extended operation or fouling of the tube bundle is suspected, the unit can be disassembled so that inspection of gasket replacement can be accomplished. The Heliflow coil is readily accessible for inspection and cleaning (if necessary) without disturbing piping. The manifold gaskets (item 5) cannot be replaced without disconnecting the tubeside connections.

1. Remove plug (item 11) to drain the casing.
2. Remove all base plate nuts (item 1).
3. Withdraw the casing, being careful not to damage the gasket (item 9).

If removal of coil is necessary:

1. Disconnect piping and remove manifold nuts (item 2) and lock rings (item 3).
2. Withdraw the coil-manifold assembly, being careful not to damage the manifold gaskets (item 5).

### ***3.2 Reassembly (See Figure I)***

1. When re-assembling, be sure manifold and base plate gaskets are intact and in place.
2. Be sure that tabs on the manifold lock rings (item 3) fit into the base plate slots. These keep the manifold-coil assembly from turning when tightening the manifold nuts and piping to the unit.
3. Be sure the bottom of the manifolds (items 6 and 7) are seated in pockets located at bottom inside of the casing.

### **3.3 Miscellaneous Notes (See Figure I)**

1. Please note that if the Heliflow has flanged, socket weld, or butt weld connections on the tubeside, unit will have the manifolds welded to the base plate, thus eliminating the manifold nuts, lock rings and manifold ring gaskets, (items 2,3, and 5) from the heat exchanger.
2. If upon initial visual inspection of unit, an external leak is evident, a gasket leak may be the cause. First, try to tighten the nuts slightly to see if the leak stops. If the leak does not stop and unit has been in operation for an extended period, a new replacement set of gaskets may be required.
3. If installing a new tube bundle, note that it may be necessary to drill a new hole in the front side of base plate to line up the tab in the lock ring. The location of the manifold keyway in relation to the existing predrilled lock ring hole may be different from the original tube bundle.

## **SECTION IV - SAFETY CONCERNS / PRECAUTIONS**

1. Before installing equipment, be sure to read the equipment nameplate for maximum allowable working pressures and design temperatures. Do not exceed these values during operation of the equipment.
2. Be sure unit is not over-pressurized. A safety relief device or over-pressure protection must be provided and installed (by others), prior to placing equipment into service.
3. Adequate support should be provided for entrance and exit piping of the heat exchanger so that loads are minimized.
4. Always start up equipment one side at a time. Typically, first the cold side and then the hot side. The exception to this rule would be for low temperature cryogenic applications. Cryogenic applications require the warmer heat transfer fluid to be circulated first, and then the cold liquid (usually liquid O<sub>2</sub> or N<sub>2</sub>) to be introduced slowly.
5. Unit should be properly vented to remove any trapped air.
6. Possible high temperature: Unit may be hot to the touch. Consider insulation of unit.
7. Do not exceed manufacturer's recommended flowrates. If no performance data sheet accompanies equipment, consult manufacturer for maximum recommended values for your specific application.
8. If pulsating pumps are used, adequate dampeners must be in place (by others).
9. Never try to open heat exchangers during operation.

## **SECTION V – SPARE AND REPLACEMENT PARTS**

Order through your nearest Graham representative or address orders directly to Graham Corporation:

GRAHAM CORPORATION  
20 Florence Avenue  
Batavia, NY 14020

Telephone: 585 / 343-2216  
Spare Parts: 800 / 828-8150  
Fax: 585 / 343-1097  
E-MAIL: spares@graham-mfg.com  
WEBSITE: <http://www.graham-mfg.com>

While Graham ships parts promptly from an extensive stock, when even a brief delay in restoring a Heliflow heat exchanger to service cannot be accepted, it is advisable to keep spare gaskets on hand. Many users also stock spare coil-manifold assemblies or one or more complete Heliflow units.

When ordering spare or replacement parts, please specify:

1. Serial number of the Heliflow unit. **This is important.**
2. Part number(s) and name(s) from the exploded view.
3. Material of construction for each component.
4. Method of shipment desired (freight, express, air express, etc.)

*Graham Corporation presents the information in this manual as good engineering practice. We cannot be held responsible for any damage to equipment that may result from mal-operation nor for any personal injuries should they occur during normal or abnormal operation.*

**Graham Corporation**

ITEM NO.	PART NAME
1	Studs & Nuts
2	Manifold Nuts
3	Manifold Lockrings
4	Baseplate
5	Manifold Gaskets
*6	Upper Manifold
*7	Lower Manifold
*8	Coil
9	Casing Flange Gasket
10	Casing
11	Vent & Drain Plugs

\* ALTHOUGH THEY ARE NUMBERED SEPARATELY, ITEMS 6, 7 & 8 ARE SOLD AS A COMPLETE ONE-PIECE FACTORY ASSEMBLY.

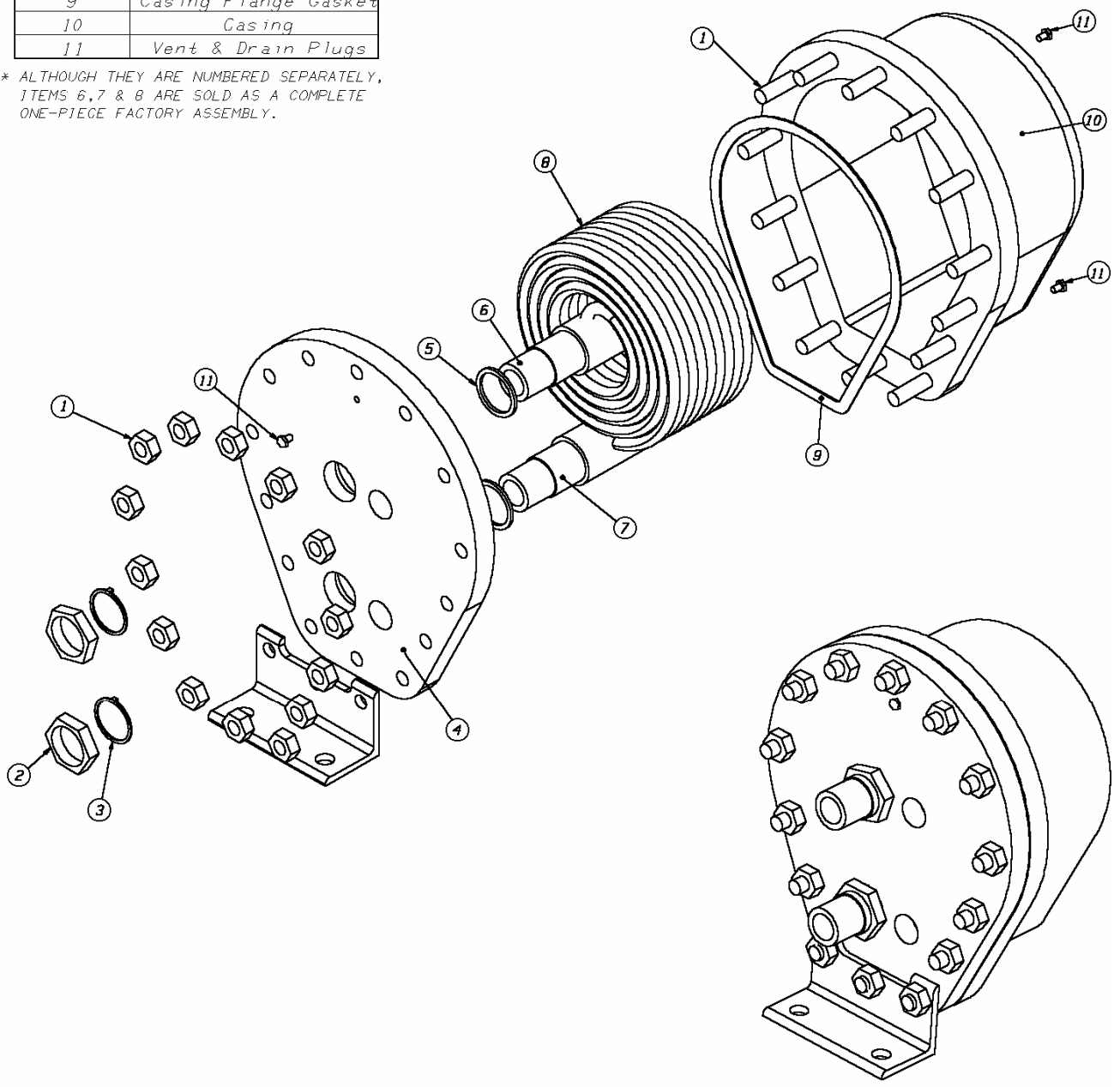

**FIGURE I**

## HELIFLOW HEAT EXCHANGER SPECIFICATION

Contact		Phone	
Company		Fax	
Street Address		Email	
City		Cust Ref	
State, Zip		Due Date	

Performance of One Unit	<u> Tubeside Fluid </u>	<u> Shell Side Fluid </u>
Fluid Name		
Total Flow Rate (lb/hr or gpm)		
Vapor (lb/hr)		
Liquid (lb/hr)		
Steam (lb/hr)		
Water (lb/hr)		
Non-condensable (lb/hr)		
Inlet Temperature (°F)		
Outlet Temperature (°F)		
* Physical Properties		
specific gravity		
specific heat (Btu/lb °F)		
thermal conductivity (Btu/hr ft °F)		
viscosity (cP) at two temperatures	cP@ °F	cP@ °F
	cP@ °F	cP@ °F
Operating Pressure (psig)		
Design Pressure (psig)		
Design Temperature (°F)		
Code Of Construction	<input type="checkbox"/> Graham Std <input type="checkbox"/> ASME	

Materials	Tubeside	Shellside
	<input type="checkbox"/> Copper (Std)	<input type="checkbox"/> Cast Iron (Std)
	<input type="checkbox"/> 304 SS	<input type="checkbox"/> Steel
	<input type="checkbox"/> 316 SS	<input type="checkbox"/> 304 SS
	<input type="checkbox"/> 70/30 Cu. Ni	<input type="checkbox"/> 316 SS
	<input type="checkbox"/> 90/10 Cu. Ni.	Other:
	<input type="checkbox"/> Admiralty	
	Other:	
Connection Type	<input type="checkbox"/> NPT (Std)	<input type="checkbox"/> NPT (Std)
	<input type="checkbox"/> Flg	<input type="checkbox"/> Flg
	<input type="checkbox"/> BW	<input type="checkbox"/> BW
	Other:	Other:

(\*) Physical properties required for uncommon fluids only

**REMARKS:**

Return this completed form via: Email: [applicationengineering@graham-mfg.com](mailto:applicationengineering@graham-mfg.com) or fax or mail to:  
 Graham Corporation • Corporate and Sales Headquarters: 20 Florence Avenue, Batavia, New York 14020 USA  
 Phone.: 585-343-2216 Fax: 585-343-1097 e-mail: equipment @ graham-mfg.com Web site:www.graham-mfg.com