



LIQUID RING PUMP

Series 3 Design

INSTALLATION, OPERATION

AND

MAINTENANCE MANUAL

Graham Corporation
20 Florence Avenue
Batavia, New York 14020
(716) 343-2216, Fax (716) 343-1097
e-mail: equipment@graham-mfg.com

IOM-LRP3-999

Table of Contents

Section 1 - General Information.....3
 1.1 Introduction.....3
 1.2 General Description and Principle of Operation.....4
 1.3 Description of Pump Model Codes.....5
Section 2 - Installation Instructions6
 2.1 Handling6
 2.2 Preservation.....6
 2.3 Mounting.....6
 2.4 Installation.....6
 2.5 Coupling Alignment7
 2.6 Belt Drives.....8
 2.7 Service Liquid Piping Arrangements8
 2.8 Shaft Seal Coolant11
 2.9 Piping Requirements11
 2.10 Electrical Requirements.....12
Section 3 - Operating Instructions 13
 3.1 Start-up Procedures.....13
 3.2 Service Liquid Requirements13
 3.3 Cavitation.....14
 3.4 Shut-Down Procedures.....15
Section 4 - Accessory Items..... 16
 4.1 Accessories.....16
Section 5 - Maintenance..... 18
 5.1 Performance.....18
 5.2 Series 3 Pump Estimated Weights (lbs.)*18
 5.3 Shaft Bearings19
 5.4 Mechanical Seals19
 5.5 Storage19
 5.6 Removal from storage.....20
 5.7 Troubleshooting Chart21
Section 6 - Disassembly And Reassembly Procedures22
 6.1 General22
 6.2 Impeller End Clearances.....22
 6.3 Tie Rod Torque Values.....24
 6.4 Bearing Data24
Section 7 - Warranty25
Appendix A - Material Safety Data Sheet.....26
Appendix B - Return Material Authorization Form.....30

Section 1 - General Information

1.1 Introduction

This manual will provide assistance in the set-up, operation, and maintenance of your Graham Liquid Ring Pump. Please read this manual completely prior to operating your Liquid Ring Pump. If you need to contact the Pump Service department for assistance, please have available the pump serial number, model number, and ID number if possible. The ID number is stamped on the edge of the discharge flange. The Pump Service department may be reached by contacting Graham Corporation in Batavia, NY by phone (716) 343-2216, Fax (716) 343-1097, or e-mail at equipment@graham-mfg.com.

Graham has an extensive stock of spare parts and replacement pumps. Stocked parts and pumps can be shipped from our warehouse in Batavia, NY, by a carrier of your choice.

For your convenience, use our toll free number (1-800-828-8150) **only** when ordering spare parts and replacement pumps. Please have the model number, serial number and part number of the items required when placing an order. Normal business hours are 8:00 a.m. to 5:00 p.m. (E.S.T.), Monday through Friday.

Factory rebuilding service is available for pumps returned to Batavia. When a pump is returned to the factory for repairs, please drain and flush the pump and include a Material Safety Data Sheet (MSDS) for the process in which the pump was used. A Return Material Authorization (RMA) Number, issued by Graham, is required before returning a pump. A sample form is included at the back of this manual to show what type of information is required to obtain an RMA Number. Field Service Technicians are also available for travel to the jobsite for troubleshooting and repair or rebuilding of pumps.

This document and the information contained herein are the property of Graham Corporation and must not be copied, in whole or in part, nor used for manufacture or otherwise disclosed without the prior written consent of the company. Information contained herein may, from time to time, be revised and/or updated. *Copyright Graham Corporation 1999*

1.2 General Description and Principle of Operation

Graham Vacuum Pumps and Compressors are of the liquid ring type. Single and two stage pumps are available in a wide range of sizes and materials. These options are listed in the Graham Sales Bulletins. The major component of the Graham pump is a multi-bladed rotating assembly positioned eccentrically in a cylindrical casing. (See Figure 1) This assembly is driven by an external source, normally an electric motor. Service liquid (usually water) is introduced into the pump. As the impeller rotates, centrifugal force creates a liquid ring which is concentric to the casing. At the inlet, the area between the impeller blades (buckets) increase in size, drawing gas in. As the impeller continues to rotate toward the discharge, the impeller bucket area decreases in size, compressing the gas. This gas, along with the liquid from the pump, is discharged through the outlet nozzle. The service liquid is separated from the gas and cooled for reuse in the pump or sent to a drain. In addition to being the compressing medium, the liquid ring performs two other important functions:

- 1) It absorbs the heat generated by compression, friction, and condensation of the incoming vapor.
- 2) It absorbs and washes out any process contaminants entrained in the gas.

A continuous supply of service liquid is necessary to limit the temperature rise in the pump caused by the heat of compression, friction, and condensation. Any excessive rise in temperature will have a detrimental effect on performance, reducing the capacity and degree of vacuum attainable. Installation schematics for the supply of the service liquid and for the separation of the gas and liquid discharged from the pump are shown in Section 2.

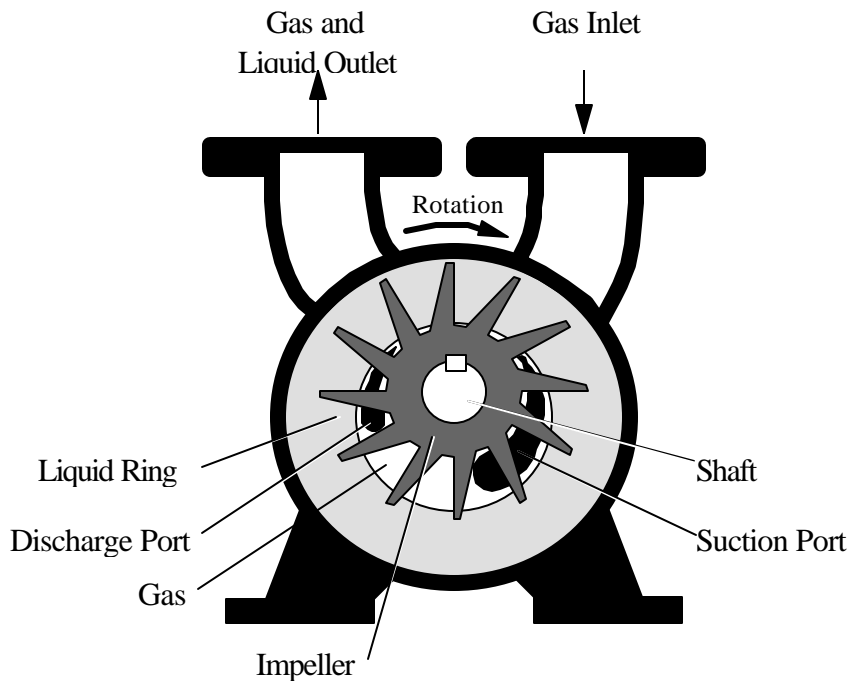

Figure 1

Graham Corporation

Service liquid quantities are a function of the particular model and the intended application. Check the data sheet for your specific pump model or see Table 1 of Section 3 which lists typical service liquid requirements.

The normal operating ranges of Liquid Ring Pumps when using water at 59° F (15 °C) for the service liquid are:

Single Stage Pumps	down to 150 mmHgA
Two Stage Pumps	down to 25 mmHgA
Two Stage Pumps w/Air Ejector	down to 3 mmHgA
Single Stage Compressors	20 psi (1.4 bar) max. differential
Two Stage Compressors	30 psi (2.1 bar) max. differential

The standard materials of construction are suitable for handling air and other non-corrosive gases, while using water as the service liquid. Other materials can be supplied for special applications.

1.3 Description of Pump Model Codes

Each pump is designated by a model code which describes the materials of construction, size, type of shaft seals, and any special features. An example of a typical pump is shown below. Contact Graham for a complete listing of the codes used to describe the pump.

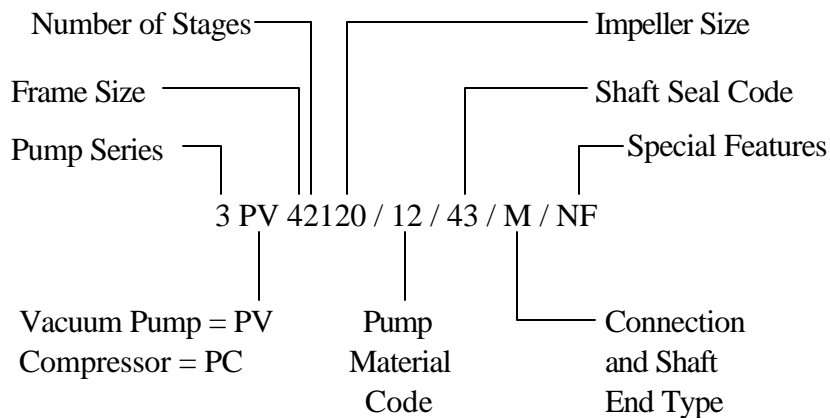

Section 2 - Installation Instructions

2.1 Handling

Carefully unpack the pump. Bare pumps may be lifted with a sling placed around the bearing housings or under the flanges.

Place slings around the motor and the pump for units supplied with C-Face motors attached.

For baseplate mounted units, lift the pump-motor assemblies by the baseplate only. Do not attach slings nor hooks to the motor or the pump as this can cause misalignment. Do not attempt to run the pump until the installation work is complete.

CAUTION: DO NOT RUN THE PUMP WITHOUT SERVICE LIQUID AND SHAFT SEAL FLUID.

2.2 Preservation

Cast Iron pumps are protected internally with a preservative solution applied at the factory before shipping. The solution should be flushed from the pump prior to use. An MSDS form is included in the back of this manual.

The preservative solution is petroleum based and must be disposed of in accordance with all Local, State, and Federal regulations.

2.3 Mounting

Before operation, the pump package should be carefully set, leveled, and securely bolted in place. It is recommended that shims and grout be used as necessary under all structural members of the base.

The Series 3 pumps are supplied as a standard to accept an adapter for mounting a NEMA C-Face motor. The pump and support bracket (adapter) should be bolted to the floor, a cement pad, or existing framework. Level and shim as required.

If baseplates are supplied with a pump and drive motor mounted at the factory, then they should be leveled, shimmed as required, and firmly anchored.

2.4 Installation

All piping to the pump should be adequately supported to eliminate any stress at the pump connections. All piping joints should be tested for leaks prior to start-up. A temporary start-up strainer in the process inlet piping may be used to keep large contaminants from entering the pump at start-up.

Graham Corporation

The location of the installation or the storage of the pump should be in an area that will not subject the pump to freezing.

Verify the pump's rotation direction by checking the arrow on the shaft end casing. Refer to section 2.10 concerning the electrical requirements.

2.5 Coupling Alignment

CAUTION: TO PREVENT PERSONAL INJURY, DO NOT OPERATE THE PUMP WITHOUT PROPERLY GUARDING THE DRIVE COUPLING.

The Series 3 pumps utilize precise machining of the pump drive end bearing housing, motor adapter, and C-Face motor flange to eliminate shaft misalignment. The coupling should be inspected before start-up.

Baseplate mounted pumps and motors supplied from the factory have had the shafts aligned prior to shipment. This ensures that alignment can be done in the field. It is *required* that the shaft alignment be rechecked after mounting on a level foundation and prior to start-up.

For smoother operation and longer life of the coupled equipment, the following maximum misalignment tolerances are recommended for baseplate mounted units:

The maximum allowable parallel shaft misalignment is ± 0.002 " (0.05 mm).

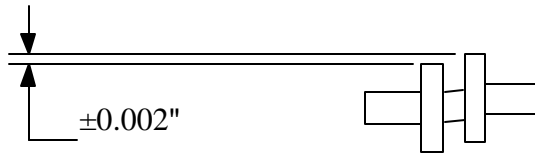

The maximum allowable angular shaft misalignment is ± 0.0005 " per inch (0.013 per mm) of coupling diameter.

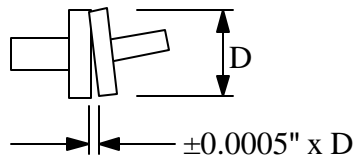

2.6 Belt Drives

CAUTION: TO PREVENT PERSONAL INJURY, DO NOT OPERATE THE PUMP WITHOUT PROPERLY GUARDING THE DRIVE BELTS.

When pumps are supplied with belt drives, follow the belt manufacturer's instructions to set the tension.

2.7 Service Liquid Piping Arrangements

The operating principle of a liquid ring pump depends on a continuous supply of clean service liquid, which is normally water. The liquid enters the pump through a connection on the casing and is discharged from the pump along with the gas. There are two basic piping arrangements that can be used for liquid ring pump applications. A once-through method with no recovery of the service liquid and a recirculation method which re-uses the service liquid.

Both of these arrangements have four basic elements:

- 1) A supply of service liquid.
- 2) A means to control flow of service liquid.
- 3) A means of stopping the flow of service liquid when the pump is off.
- 4) A means of separating the gas / liquid exhaust mixture.

It is recommended to use a strainer to ensure that foreign matter does not enter the pump with the service liquid supply or make-up source. See Diagrams 1 and 2 for the proper piping arrangement scheme.

CAUTION: COMPLETE ALL PIPING INSTALLATION AND MAKE SURE A SUPPLY OF SERVICE LIQUID IS AVAILABLE BEFORE STARTING THE PUMP.

Graham Corporation

A) Typical Installation of Once Through with No Recovery

The service liquid is piped directly from a supply source to the pump. The liquid is separated from the gas in the separator and discharged to a drain. No recirculation nor recovery takes place. This is the most basic arrangement and can be used when service liquid conservation or contamination is not a concern. A solenoid operated valve provides for flow of the liquid simultaneously with the pump/motor operation. When the motor stops, the valve closes to prevent the pump casing from filling with fluid. The by-pass valve is used to pre-fill the pump at initial start-up only. It also can be used should the solenoid fail. When a manual valve is used, it must be opened immediately after starting the motor and closed immediately before turning the motor off.

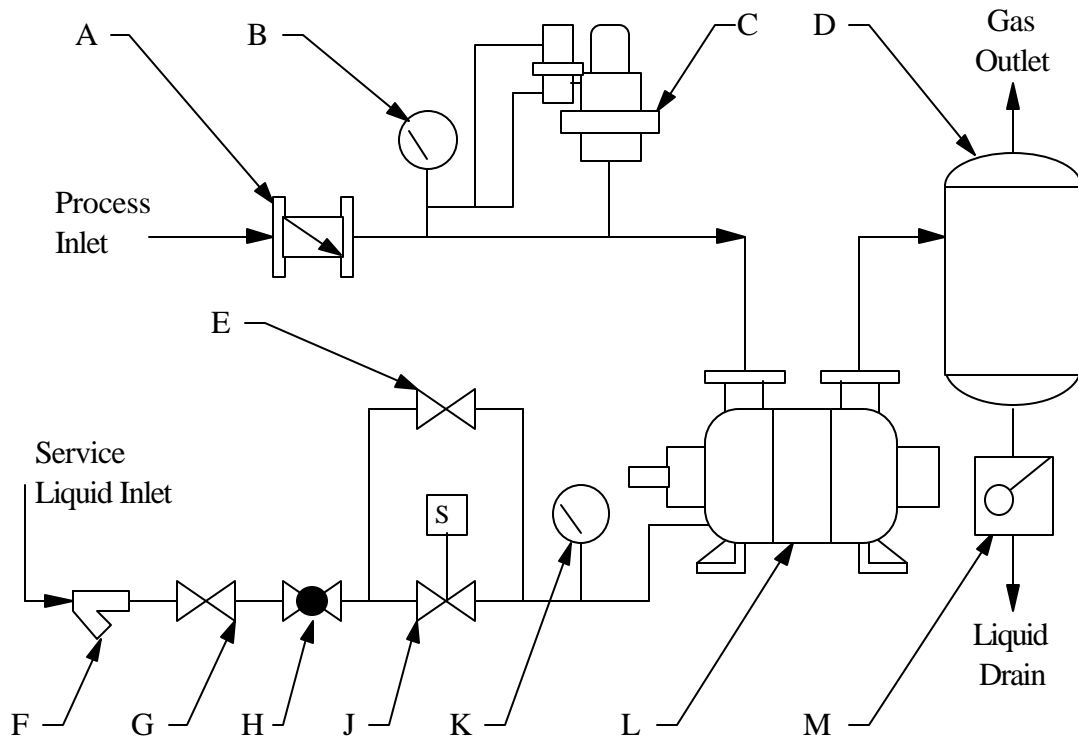

- | | |
|--|--|
| A- Inlet Check Valve | G- Shut-off Valve |
| B- Pressure Gauge (vacuum gauge for vacuum service or compound gauge for compressor service) | H- Regulating Valve |
| C- Vacuum Relief Valve (not required for compressor service) | J- Solenoid Valve |
| D- Separator | K- Compound Gauge |
| E- By-Pass Valve | L- Liquid Ring Pump |
| F- Strainer | M- Trap (required if discharge pressure is above atmospheric pressure) |

Once Through with No Recovery
Diagram 1

Graham Corporation

B) Typical Installation of Closed Loop with Total Recovery

This arrangement provides for the total recirculation of the service liquid. A heat exchanger is added to the system to remove the heat of compression, friction, and condensation from the service liquid before it is re-introduced to the pump.

The service liquid level in the separator of a total recovery system should be at or slightly below the centerline of the pump shaft. A provision should be made for a high level overflow. This will prevent starting the pump while it is full of liquid, which will damage the pump or overload the motor.

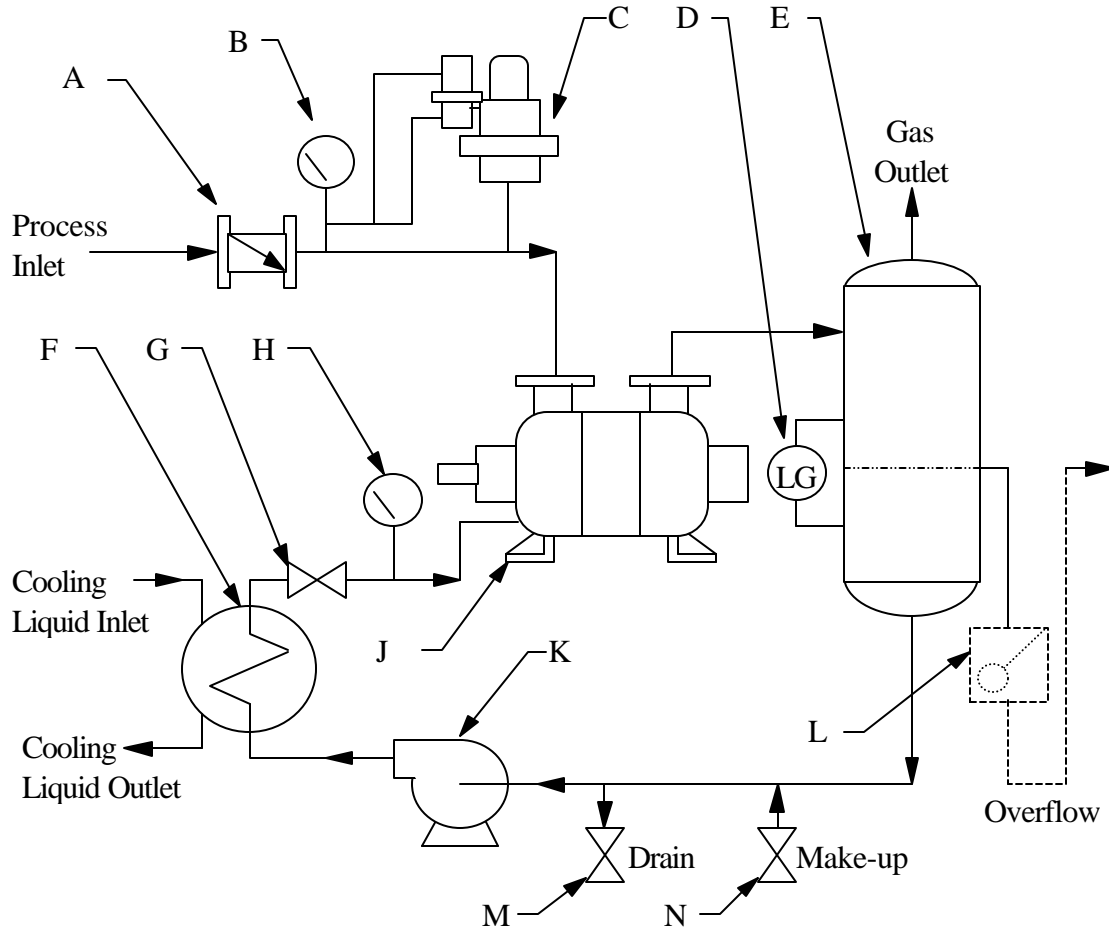

- | | |
|--|---|
| A- Inlet Check Valve | G- Shut-off or Throttling Valve |
| B- Pressure Gauge (vacuum gauge for vacuum service or compound gauge for compressor service) | H- Compound Gauge |
| C- Vacuum Relief Valve (not required for compressor service) | J- Liquid Ring Pump |
| D- Level Gauge | K- Recirculation Pump (recommended) |
| E- Separator | L- Trap or Loop Seal (required if discharge pressure is above atmospheric pressure) |
| F- Service Liquid Cooler | M- Drain Valve |
| | N- Make-Up Valve |

Closed Loop-Total Recovery

Diagram 2

Graham Corporation

C) Draining Before Start-Up

CAUTION: DO NOT START THE PUMP WITH THE CASING FULL OF LIQUID.

A Liquid Ring Pump should not be started with the casing full of liquid. Damage to the impeller(s) or the shaft will result. The normal liquid level should be no higher than the shaft centerline. The pump may be started with a low liquid level as long as a supply of service liquid is available immediately after start-up.

2.8 *Shaft Seal Coolant*

The Series 3 pumps are available with mechanical seals only. The mechanical seals are flushed and cooled internally by the ring liquid in the pump. No separate external source of shaft seal coolant is required.

2.9 *Piping Requirements*

A) Suction and Discharge Piping

The suction and discharge connections on the pump are arranged vertically and are marked with arrows on the pump casing. The suction and discharge piping should be the same nominal size as the pump connections. The elevation of the discharge separator above the discharge connection should be limited to an elbow turning horizontally.

The inlet and outlet connections on the Series 3 pumps are as listed. USA x metric mating flanges can be supplied.

•	Frame size 20000	BSP threaded connections
•	Frame size 30000 - 50000	DIN, PN 10 flanged connections

If necessary, a discharge leg can be used with a maximum of 24 inches (610 mm) above the pump discharge flange. Too high an elevation in this line will cause excessive backpressure on the pump, overload the motor, and reduce the pump capacity.

Remove the protective coverings from the pump openings just before attaching the piping. Check that all foreign matter such as weld slag, nuts, bolts, rags, and dirt has been cleaned out of the piping before connecting to the pump. The piping flanges must fit easily and without strain on the pump flanges and the flange bolt holes must be in alignment. The flange gaskets must not protrude into the bore of the piping or pump flanges. All piping must be supported independently on each side of the pump without transmitting any strain to the pump casing. A temporary suction strainer fitted at the suction inlet is recommended during the first 100 hours of operation.

Graham Corporation

B) Service Liquid Piping

In a once-through arrangement, the nominal pipe size should be the same size as the service liquid connection. In a total recirculation package with no recirculation pump, use one nominal pipe size larger than the service liquid connection of the pump. Also, use the least number of fittings to minimize the pressure drop. When a recirculation pump is used, the piping should be the same size as the service liquid connection.

The service liquid connection on the Series 3 pump is a BSP pipe thread. An NPT x BSP adapter can be supplied.

2.10 Electrical Requirements

All electrical wiring and installation must comply with local safety codes.

After the electrical work is complete, the motor should be jogged to check for proper rotation. First, turn the pump by hand to see that it rotates freely. The direction of rotation is marked on the pump. Second, jog the motor momentarily to check the rotation. It is recommended to use a non-reversing motor controller to prevent the pump from turning in the wrong direction.

Section 3 - Operating Instructions

3.1 Start-up Procedures

Read all instructions before proceeding.

- 1) Turn the shaft manually to ensure it rotates freely. If the pump is binding or seized, refer to the troubleshooting chart in Section 5.
- 2) Fill the pump with service fluid to the shaft centerline, but do not overfill

CAUTION : DO NOT RUN THE PUMP WITHOUT SERVICE LIQUID AND SHAFT SEAL FLUID.

- 3) The normal service liquid level should be no higher than the shaft centerline. The pump may be started with a low service liquid level as long as a supply is available immediately after start-up.
- 4) Open any valves in the suction and discharge lines.
- 5) Confirm the pump rotation with the arrow on the casing by jogging the motor.
- 6) Start the motor, ensure service liquid supply, and set regulating valve, when used, for optimum pump performance.

3.2 Service Liquid Requirements

A) Flow Rates

Service liquid flow rates depend on the type of piping arrangement used, the size and operating speed of the pump, and the allowable temperature rise through the pump. Nominal flow rates for standard pumps and compressors at normal conditions are given in Table 1.

Service liquid flow rates and the temperature rise are important because of their effect on pump performance. Too little flow will result in loss of capacity. Too much flow will result in excessive horsepower requirements.

Service Liquid Flow Rates*

Single Stage Pumps		Two Stage Pumps	
Pump Model	USGPM	Pump Model	USGPM
3PV21030	1	3PV22030	2
3PV21070	2	3PV22070	3
3PV31060	4	3PV22090	3
3PV31110	4	3PV32080	4
3PV41160	6	3PV42110	6
		3PV42160	6
		3PV52120	8
		3PV52160	8
		3PV52200	10

* Flowrates apply to PV or PC design. For units in m³/hr, multiply USGPM by 0.227

Table 1

Graham Corporation

B) Flow Control

If a flow device is not used to measure the service liquid quantity to the pump, a regulating valve and compound gauge in the service liquid line can be used to approximate the flowrate. For pump operating pressures between atmospheric and 400 mmHgA, the reading on the compound gauge should be in the range of 2" HgV to 5 psig (709 mmHgA to 0.35 barg). For operating pressures below 400 mmHgA, the compound gauge reading should be in the range of 15" HgV to 2 psig (379 mmHgA to 0.14 barg). This method is only an approximation of the service liquid quantity. The actual operating conditions will dictate the amount of sealant liquid required and also the compound gauge reading.

On some closed loop - total recirculation type systems, the vacuum pump will draw the amount of service liquid from the discharge separator tank that it requires. No other flow control device needs to be installed on this type of system.

C) Hard Water

If hard water is used as the service liquid, scale deposits caused by the precipitation of minerals will occur. This will vary with the temperature of the water. Scale deposits on the internal surfaces of the pump will cause an increase of the operating horsepower, wear on moving parts, and may cause the pump to seize. If the hardness of the water is excessive, consider using a water softening treatment.

3.3 Cavitation

Cavitation is identified by a characteristic metallic or grinding noise inside the pump. It is caused when the pump suction pressure is too close to the vapor pressure of the service liquid. If the service liquid temperature inside the pump rises such that its vapor pressure closely approaches the suction pressure of the pump, cavitation will occur.

When cavitation takes place, vapor bubbles form and collapse within the liquid ring. This will damage the surfaces of the impeller, side plates, and casing. Cavitation causes damage by tearing away metal particles. The damage may be more severe in a corrosive situation.

Cavitation may be prevented by bleeding air into the pump to raise the suction pressure. Vacuum relief valves can be fitted in the suction piping for this purpose. If the pump is provided with an air attenuation valve, it can be opened to bleed air into the second stage casing until the noise stops.

If the problem is not caused by a low flow of non-condensable gases, the service liquid temperature should be checked. Ultimately, the vacuum at which the pump can be operated is governed by the vapor pressure of the service liquid inside the pump.

3.4 Shut-Down Procedures

- 1) Shut off the service liquid supply and immediately stop the motor.
- 2) If necessary, close all suction and discharge valves.
- 3) If necessary, drain the pump to protect it from freezing by removing all drain plugs.
- 4) Disconnect power from the motor if maintenance is to be performed.

Section 4 - Accessory Items

4.1 Accessories

There are many accessory items associated with Liquid Ring Vacuum Pumps and Compressors. They can be supplied by Graham and shipped from the factory or can be supplied by others and installed in the field. The particular requirements, mode of operation, and type of control scheme desired dictate the necessity of various items. The following is a list of common accessories.

Inlet Check Valve	Used to prevent a back flow of gas into the process when the pump is stopped. Check valves are normally installed in a horizontal line. An elbow can be provided to adapt the vertical pump inlet to accept a horizontal check valve.
Vacuum Relief Valve	Used to protect the pump from cavitation and control the pump suction pressure. When the pump capacity exceeds the system's flow requirements at a pre-determined level, the valve will open and bleed in atmospheric air or process gas.
Flexible Connector	Used to compensate for minor misalignment or expansion between the pump connections and the process piping.
Vacuum Gauge	Used to indicate vacuum at the pump inlet. Normally mounted directly ahead of the pump suction.
Shut-off Valve	Used to manually stop the flow of service liquid to the pump.
Strainer	Used to filter out solid particles that will damage the pump.
Flow Regulator	Used to control the service liquid flow rate to the pump. A manual valve, a fixed orifice, or a flexible element orifice may be used depending on the application.
Compound Gauge	Used to indicate pressure in the service liquid piping.
Discharge Separator	Used to separate the service liquid from the discharged gas as it comes out of the pump. The liquid can be piped to a drain or recovered for reuse.
Solenoid Valve	Used to automatically stop or start the flow of service liquid to the pump. Normally interlocked to the pump motor.
By-pass Valve	Used to initially fill the pump with service liquid or for bypass in case the solenoid coil fails.

Graham Corporation

- Recirculation Pump Used to circulate the service liquid recovered from the discharge separator in some total recovery systems.
- Heat Exchanger Used to remove heat from the recirculated service liquid.
- Atmospheric Air Ejector Used to provide a suction pressure lower than the pump is capable of when operating alone. It may be added to a two stage pump to provide an inlet pressure as low as 3 mm HgA. The operation of the air ejector is similar to that of a steam ejector. Atmospheric air or recycled gas from the discharge separator is used as the motive force for compressing the process gas from the system design pressure up to the inlet pressure of the pump. To enhance pumping capacity at a higher suction pressure, an optional motive air shut-off valve or by-pass valve can be added. (See Figure 2)

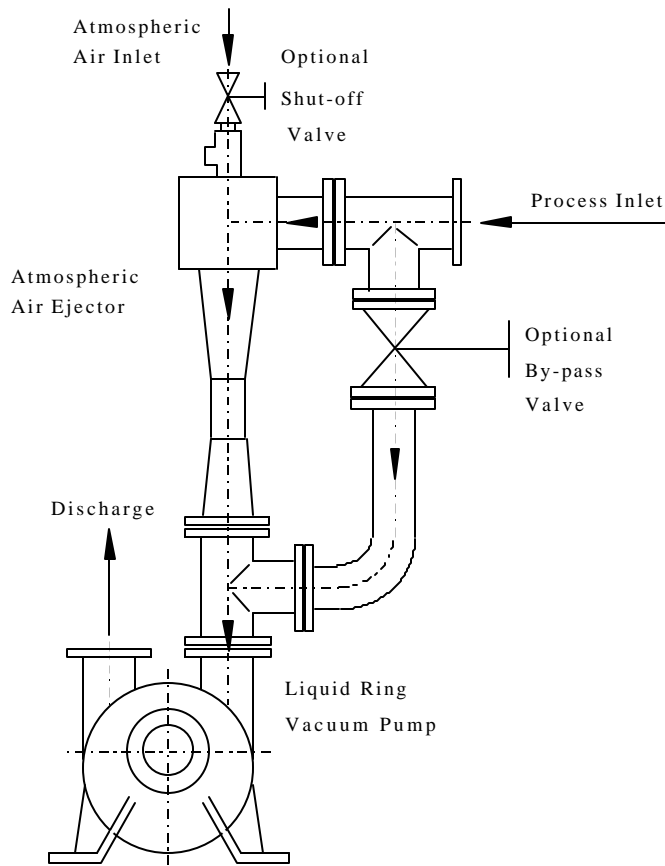

Typical Atmospheric Air Ejector

Figure 2

Section 5 - Maintenance

5.1 Performance

Optimum performance and long service life are dependent upon good maintenance procedures and periodic inspections. When preparing to dismantle a pump, make provisions for the safe handling of heavy parts.

5.2 Series 3 Pump Estimated Weights (lbs.)*

Cast Iron								
Pump Model	Dry	Operating	Flooded		Pump Model	Dry	Operating	Flooded
3PV21030	51	54	56		3PV22030	55	58	61
3PV21070	53	56	58		3PV22070	62	65	68
3PV31060	88	92	97		3PV22090	66	69	73
3PV31110	132	142	151		3PV32080	100	110	120
3PV41160	176	188	200		3PV42110	187	200	207
					3PV42160	192	209	227
					3PV52120	342	364	386
					3PV52160	377	403	430
					3PV52200	397	428	459

Stainless Steel								
Pump Model	Dry	Operating	Flooded		Pump Model	Dry	Operating	Flooded
3PV21030	N/A	N/A	N/A		3PV22030	N/A	N/A	N/A
3PV21070	N/A	N/A	N/A		3PV22070	N/A	N/A	N/A
3PV31060	93	97	102		3PV22090	N/A	N/A	N/A
3PV31110	139	149	159		3PV32080	105	116	126
3PV41160	185	197	210		3PV42110	196	210	217
					3PV42160	202	220	238
					3PV52120	359	382	405
					3PV52160	396	423	452
					3PV52200	417	449	482

* Pump weights apply to PV or PC design. For units in kg, multiply lbs. by 0.454

Table 2

5.3 Shaft Bearings

The Series 3 pumps use sealed-for-life bearings that are not regreasable.

The standard bearings are rated for an L10_h life of 80,000 hours. The temperature of the bearings should not exceed 140°F (60°C). Overheating may be due to misalignment of the shafts or a bad bearing.

5.4 Mechanical Seals

The Series 3 pumps are fitted with single acting mechanical shaft seals. They should be replaced when worn, scratched, or cracked, or when the rotating segment no longer grips the shaft.

When replacing the mechanical seals, clean the shaft thoroughly. The seal faces must be protected during installation from particles which may scratch the surfaces.

CAUTION: DO NOT RUN THE PUMP WITHOUT SERVICE LIQUID AND SHAFT SEAL FLUID.

5.5 Storage

If a pump is to be out of service, it should be protected internally from rusting by using a rust inhibitor. The pump should be drained completely by removing all the lower plugs. Install the plugs and fill with Oakite HPO (or equal) preservative solution. Remove the manifold(s) and spray the insides with preservative. Rotate the pump manually to circulate the solution. Drain the pump to below the shaft centerline and replace the manifold(s). This procedure may be disregarded for pumps made of stainless steel.

Seal any openings to prevent foreign material from entering the pump.

The pump shaft should be rotated each week to distribute the preservative and to prevent flat spots on the bearings. Document the time, date, and by whom this procedure was performed.

The manifold(s) should be re-sprayed monthly and the pump checked to see that the preservative is maintained. This will protect the pump for up to twelve months.

Pumps stored at low temperatures may need to be protected from freezing either by draining completely or by using an anti-freeze solution.

Pumps with V-belt drives should have the belts loosened to relieve the belt tension during storage. Do not store near running electric motors as ozone produced is detrimental to the rubber in the belts.

5.6 Removal from storage

The pump should be drained and flushed if necessary to remove the preservative solution. Refer to Section 3.1 of this manual for the recommended start-up procedure.

CAUTION: THE OAKITE HPO PRESERVATIVE SOLUTION IS PETROLEUM BASED AND MUST BE DISPOSED OF IN ACCORDANCE WITH ALL LOCAL, STATE, AND FEDERAL REGULATIONS.

An MSDS form is included in the back of this manual.

5.7 Troubleshooting Chart

Problem	Cause	Solution
Reduced Capacity	<ul style="list-style-type: none"> • Speed too low • Leak in suction line • Service liquid temperature too high • Insufficient or excess service liquid • Excessive back pressure 	<ul style="list-style-type: none"> • Check power supply and transmission • Repair • Check coolant flow & heat exchanger • Provide correct flow rate • Eliminate cause of back pressure
Excessive Noise	<ul style="list-style-type: none"> • Excessive or insufficient service liquid • Shaft misalignment • Defective bearing • Cavitation • Back pressure 	<ul style="list-style-type: none"> • Adjust flow rate • Realign shafts • Replace bearing • Open attenuation valve or adjust vacuum relief valve • Eliminate cause of back pressure
High Power Consumption	<ul style="list-style-type: none"> • Excessive service liquid • Shaft misalignment • Excessive back pressure • Defective bearing • Improperly mounted pump 	<ul style="list-style-type: none"> • Reduce flow rate • Realign shafts • Eliminate cause of back pressure • Replace bearing • Make sure surface is level and all feet touch the surface, shim if necessary.
Overheating	<ul style="list-style-type: none"> • Service liquid temperature too high • Insufficient service liquid • Shaft misalignment • Defective bearing 	<ul style="list-style-type: none"> • Check coolant flow & heat exchanger • Provide correct flow rate • Realign shafts • Replace bearing
Vibration	<ul style="list-style-type: none"> • Shaft misaligned • Pump or baseplate not properly anchored • Defective bearing • Improperly mounted pump • Cavitation • Back pressure • Excessive service liquid 	<ul style="list-style-type: none"> • Realign shafts • Anchor • Replace bearing • Make sure surface is level and all feet touch the surface, shim if necessary. • Open attenuation valve or adjust vacuum relief valve • Eliminate cause of back pressure • Provide correct flow rate
Abnormal Bearing Wear or Failure	<ul style="list-style-type: none"> • Shaft misalignment • Piping load on pump flange • Mechanical seal leakage • Shaft flinger missing 	<ul style="list-style-type: none"> • Realign shafts • Support connecting pipe work • Replace seals • Replace flinger
Shaft Will Not Turn or Partially Seizes	<ul style="list-style-type: none"> • Scale build-up • Foreign object in pump • Piping load on pump flange • Improperly mounted pump • Soft Foot 	<ul style="list-style-type: none"> • Descale pump • Remove foreign object • Support connecting pipe work • Make sure surface is level and all feet touch the surface, shim if necessary. • Correct pump / motor mounting

Table 3

Section 6 - Disassembly And Reassembly Procedures

6.1 General

Complete disassembly of the pump is seldom necessary and it may only need to be disassembled to the point required to repair or service it. Specific instructions are included with the documentation sent with your liquid ring pump. The cross-section drawing and parts list should be referred to when servicing the pump and when ordering spare parts.

Before any servicing takes place, it is recommended that gasket compound, bearings, and mechanical seals be on hand as spare parts. The stocking of additional items beyond these basic wearing parts is dependent upon the type of application, compatibility of pump materials with the process gas and service liquid, degree of corrosion and erosion to which the pump is subjected, importance of pump reliability to the process, etc.

When ordering spare parts, be sure to identify the pump size, serial number, part name and reference number, and if available, original purchase order number, Graham job number, or a drawing number.

6.2 Impeller End Clearances

Refer to Table 4 for the impeller end clearances. These values are for each side of the impeller in each stage. These clearances are extremely important for optimum pump performance. Also refer to the dismantling and reassembly procedures that were provided with the documentation sent with your pump.

Impeller End Clearances *

Pump Frame Size	Cast Iron Construction	316SS Construction
30000	0.004"-0.006"	0.006"-0.009"
40000	0.004"-0.006"	0.006"-0.009"
50000	0.006"-0.008"	0.009"-0.012"

* For units in mm, multiply inches by 25.4

Table 4

Graham Corporation

A) Non-Gasketed Pumps

Series 3 pumps do not require casing gaskets, but use a joint sealing compound between the impeller casings and the end plates. They are machined for a metal to metal fit. Refer to Figures 3 & 4. The headers or crossover manifolds require a gasket.

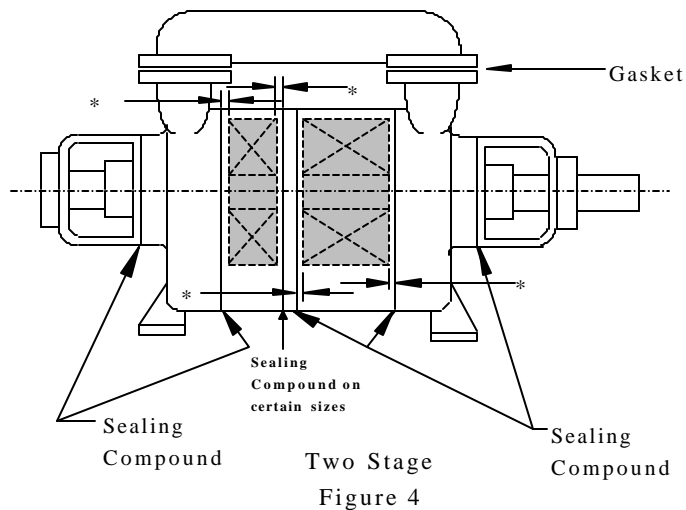
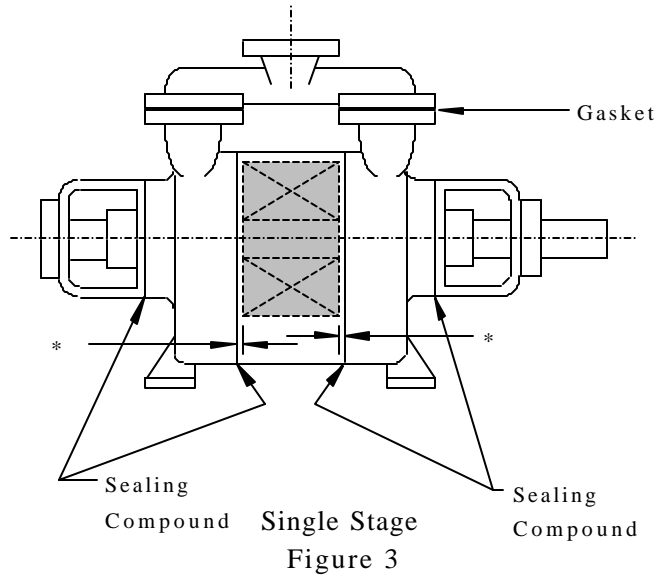

* Impeller clearance locations.

6.3 Tie Rod Torque Values

Table 5 includes torque values for re-assembling the pumps.

Pump Frame Size	Tie Rod Torque *
20000	30 ft.-lbf
30000	40 ft.-lbf
40000	40 ft.-lbf
50000	40 ft.-lbf

* For units in N-m, multiply ft.-lbf by 1.355

Table 5

6.4 Bearing Data

The correct bearing fit class needs to be used in order for proper operation. **Do not use a C3 fit as it is too loose and will cause damage to the pump.** Table 6 provides correct bearing data for the pumps.

Pump Frame Size	SKF Bearing Number	Type	Bearing Fit Class (Normal Fit)	Bearing Journal Diameter & Tolerance (µm)	Tolerance Class
30000	6306/2RS1	Ball Bearing, Single Row, Deep Groove,	AFBMA 0	30 mm, +15, +2	k6
40000	6306/2RS1		AFBMA 0	30 mm, +15, +2	k6
50000	6308/2RS1	Double Seals (SFL)	AFBMA 0	40 mm, +18, +2	k6

Table 6

Section 7 - Warranty

THE FOLLOWING IS IN LIEU OF ALL WARRANTIES OF GRAHAM EXPRESSED OR IMPLIED AND ALL IMPLIED WARRANTIES, INCLUDING BUT NOT LIMITED TO ANY IMPLIED WARRANTY OF MERCHANTABILITY OR FITNESS FOR A PARTICULAR PURPOSE, AND/OR ANY OTHER OBLIGATION ON THE PART OF GRAHAM ARE HEREBY EXCLUDED:

Graham, except as otherwise provided, warrants goods of its own manufacture against faulty workmanship or the use of defective materials, under normal use and service, and that such goods will conform to mutually agreed upon written specifications, drawings, and is guaranteed to meet specified performance requirements, for a period of twelve (12) months from date of shipment of the goods from the factory.

Graham assumes no responsibility for deterioration of the equipment due to corrosion, erosion, or flow induced tube vibration, or for fouling, maintenance problems or any other causes not specifically covered under the foregoing warranty. The sole remedy of Buyer with respect to any part not conforming to any warranty of Graham shall be the repair or, at Graham's option, replacement of any defective part at the point of manufacture, Buyer assuming all costs of removal, shipping, and reinstallation, provided that immediate written notice of the defect has been given to Graham, and Graham shall not be liable for any other expenses incurred because of failure of any part to meet Graham's warranty, nor for any special, indirect or consequential damages. Material returned to Graham's factory without its written consent will not be accepted. No back charges will be honored without Graham's advance approval of the work to be performed. Graham's liability on any claim of any kind, including negligence, for any loss or damage arising out of, connected with, or resulting from this transaction, or the design, manufacture, sale, delivery, resale, installation, technical direction of installation, inspection, repair, operation, or use of any equipment covered by or furnished hereunder shall in no case exceed the price paid by Buyer for the equipment. Graham also disclaims all liability, whether in contract, tort, warranty, or otherwise, to any party other than the Buyer.

In the event the pumps are altered or repaired by any person or entity other than Graham, without written approval by Graham, all warranties are void. Bearings and shaft seals are warranted only to the extent of, and pursuant to, the original manufacturer's warranty

Appendix A- MATERIAL SAFETY DATA SHEET



4405

MATERIAL SAFETY DATA SHEET

PRODUCT CODE: 4405
 OAKITE HPO
 200-238-001

HMIS 2 2 1 H

SECTION I - PRODUCT IDENTIFICATION

TRADE NAME OAKITE HPO EMERGENCY TELEPHONE NUMBER:
 CHEMICAL NAME (800) 424-9300 (CHEMTREC)
 AND SYNONYMS NA; Mixture.
 MANUFACTURER'S NAME AND TELEPHONE NO. OAKITE PRODUCTS INC. (908) 464-6900 (8am-5pm)
 A Member of The CHEMETALL Group
 ADDRESS 50 Valley Road Berkeley Heights NJ 07922
 DATE OF PREPARATION 05-21-98

SECTION II - HAZARDOUS INGREDIENTS

	CAS NO.	% BY WT	ACGIH TLV (TWA)	OSHA PEL (TWA)	UNITS
Severely hydrotreated naphthenic petroleum distillate -(as oil mist, mineral)	0064742525	60-70	5	5	mg/m ³
Kerosene	0008008206	15-25	NE	NE	
Barium sulfonate(+) (as Ba, soluble compounds)	0061790485	1-10	0.5	0.5	mg/m ³
2-Butoxyethanol(+) -(skin)	0000111762	1-5	25	50	ppm
Non-hazardous ingredients		Bal.			

Unidentified ingredients are considered not hazardous under Federal Hazard Communication Standard (29CFR 1910.1200).

All components of this material are on the US TSCA Inventory.

(+) This product contains ingredient(s) identified in Section II with (+) which are subject to the reporting requirements of Section 313 of SARA Title III and 40 CFR 372.

CARCINOGENICITY: No substance in this product is listed by IARC, NTP, or regulated by OSHA as a carcinogen.

Oakite Products Inc. warrants that the product or products described herein will conform with its published specifications. The products supplied by Oakite and information related to them are intended for use by buyers having necessary industrial skill and knowledge. Buyers should undertake sufficient verification and testing to determine the suitability of the Oakite materials for their own particular purpose. Since buyer's conditions of use of products are beyond Oakite's control, Oakite does not warrant any recommendations and information for the use of such products. OAKITE DISCLAIMS ALL OTHER WARRANTIES INCLUDING THE IMPLIED WARRANTY OF MERCHANTABILITY AND FITNESS FOR ANY PARTICULAR PURPOSE IN CONNECTION WITH THE USE OF ITS PRODUCTS.

NA - Not Applicable **NE - Not Established**

MATERIAL SAFETY DATA SHEET
 =====
SECTION III - PHYSICAL DATA
 =====

BOILING POINT (F)	NE	SPECIFIC GRAVITY (H2O=1)	0.890
VAPOR PRESSURE (mm Hg)	NE	Bulk Density	7.4 lb/gal
VAPOR DENSITY (Air=1)	NE	PERCENT VOLATILE	
SOLUBILITY IN WATER	Insoluble	BY WEIGHT(%) Excludes H2O	15-25
EVAPORATION RATE (Water=1)	<1	PH	NA
APPEARANCE AND ODOR	Reddish-brown liquid; spicy, pungent odor.	PH (concentrate)	NA

 =====
SECTION IV - FIRE AND EXPLOSION HAZARD DATA
 =====

FLASH POINT (Method Used): 170 F (TCC)
 FLAMMABLE LIMITS: LEL: NE UEL: NE

EXTINGUISHING MEDIA: Carbon dioxide, dry chemical, or foam.

SPECIAL FIRE FIGHTING PROCEDURES: Wear Self-Contained Breathing Apparatus (SCBA).

UNUSUAL FIRE AND EXPLOSION HAZARDS: See Section VII. (WHMIS)
 See Section VI. (U.S.)

 =====
SECTION V - HEALTH HAZARD INFORMATION
 =====

ROUTE(S) OF ENTRY:	INHALATION:	SKIN:	INGESTION:
	x	x	x

MEDICAL CONDITIONS AGGRAVATED BY EXPOSURE: None known.

SYMPTOMS/EFFECTS OF OVEREXPOSURE:

Inhalation of mist may cause respiratory irritation. High vapor concentrations may produce headache, dizziness and nausea. Product contains 2-butoxyethanol which has shown to cause liver and kidney damage and hemolytic anemia in test animals. Direct contact with eyes causes irritation. Chronic exposure may lead to skin irritation, oil acne, and dermatitis.

FIRST AID

EYES: Immediately flush eyes with plenty of water for at least 15 minutes while holding eyelids open. If irritation persists get medical attention.

NA - Not Applicable

NE - Not Established



MATERIAL SAFETY DATA SHEET

SKIN: Remove contaminated clothing. Wash thoroughly with soap and water. If irritation persists, get medical attention.

INGESTION: Contact local poison control center or physician IMMEDIATELY!

INHALATION: Move victim to fresh air. Treat symptomatically.

=====

SECTION VI - REACTIVITY DATA

=====

STABILITY: NORMALLY STABLE
Avoid extreme heat, open flame.

INCOMPATIBLE MATERIALS: Acids, Strong oxidizers.

HAZARDOUS DECOMPOSITION PRODUCTS: Carbon monoxide, Carbon dioxide, Sulfur dioxide.

=====

SECTION VII - SPILL OR LEAK PROCEDURES

=====

PROCEDURES: Wear personal protective equipment (See Section VIII).
Ventilate area. Remove all heat and ignition sources. Clean up with noncombustible absorbant material.

WASTE DISPOSAL METHOD: Dispose of in accordance with Local State and Federal regulations.

=====

SECTION VIII - SPECIAL PROTECTION INFORMATION

=====

RESPIRATORY: For symptoms of overexposure, wear a NIOSH-approved organic vapor respirator with a dust and mist pre-filter.

EYEWEAR: Wear chemical safety goggles.

CLOTHING/GLOVES: Wear neoprene or other chemical-resistant gloves and clothing as needed to prevent skin contact.

VENTILATION: Local exhaust may be necessary for some handling/use conditions. Specific needs should be addressed by supervisory or health/safety personnel.

=====

SECTION IX - SPECIAL PRECAUTIONS

=====

NA - Not Applicable

NE - Not Established

Oakite®

4405

MATERIAL SAFETY DATA SHEET

COMBUSTIBLE. Keep away from heat, sparks, open flame. Store in closed container in cool well-ventilated area.

APPROVAL *Michael Chang* Mgr. Health & Environmental Dept. 05/21/199
NAME **TITLE** **DATE OF PRINT**

NA - Not Applicable

NE - Not Established

-4-

Appendix B- RETURN MATERIAL AUTHORIZATION FORM

RETURN MATERIAL AUTHORIZATION FORM

TO: Pump Service Department

Date: _____

FROM: _____

RMA Number: _____

This form must be filled out completely before any work will be started on the equipment being returned. This is to ensure the safety of all Graham employees who may come in contact with this equipment.

MSDS (Material Safety Data Sheet) must be included for all material handled by the equipment. Work on the equipment will be held pending receipt of the MSDS.

The equipment must be cleaned prior to shipping back to Graham. Equipment returned in an unsatisfactory condition will be returned to the sender for cleaning.

Customer Data

A

Customer: _____ **M**

Contact Person: _____

Mailing Address: _____

Phone Number: _____

Pax Number: _____

L

Graham Equipment Information

Graham Serial Number: _____

E

Equipment Being Returned: _____

Reason for Return: _____

Material Handled by Equipment: _____

Send equipment and MSDS sheets to the address above, Attn.: Pump Service Dept.

This form is to be filled out by Graham (Batavia) personnel only. RMA forms filled out by agents and customers will not be accepted!